

74HC4053; 74HCT4053

Triple 2-channel analog multiplexer/demultiplexer

Product data sheet

1. General description

The 74HC4053; 74HCT4053 is a high-speed Si-gate CMOS device and is pin compatible with the HEF4053B. It is specified in compliance with JEDEC standard no. 7A.

The 74HC4053; 74HCT4053 is triple 2-channel analog multiplexer/demultiplexer with a common enable input (\bar{E}). Each multiplexer/demultiplexer has two independent inputs/outputs ($nY0$ and $nY1$), a common input/output (nZ) and three digital select inputs (S_n).

With \bar{E} LOW, one of the two switches is selected (low-impedance ON-state) by $S1$ to $S3$. With \bar{E} HIGH, all switches are in the high-impedance OFF-state, independent of $S1$ to $S3$.

V_{CC} and GND are the supply voltage pins for the digital control inputs ($S1$ to $S3$ and \bar{E}). The V_{CC} to GND ranges are 2.0 V to 10.0 V for 74HC4053 and 4.5 V to 5.5 V for 74HCT4053. The analog inputs/outputs ($nY0$ and $nY1$, and nZ) can swing between V_{CC} as a positive limit and V_{EE} as a negative limit. $V_{CC} - V_{EE}$ may not exceed 10.0 V.

For operation as a digital multiplexer/demultiplexer, V_{EE} is connected to GND (typically ground).

2. Features

- Low ON resistance:
 - ◆ 80 Ω (typical) at $V_{CC} - V_{EE} = 4.5$ V
 - ◆ 70 Ω (typical) at $V_{CC} - V_{EE} = 6.0$ V
 - ◆ 60 Ω (typical) at $V_{CC} - V_{EE} = 9.0$ V
- Logic level translation:
 - ◆ To enable 5 V logic to communicate with ± 5 V analog signals
- Typical 'break before make' built in
- Complies with JEDEC standard no. 7A
- ESD protection:
 - ◆ HBM EIA/JESD22-A114-C exceeds 2000 V
 - ◆ MM EIA/JESD22-A115-A exceeds 200 V
- Multiple package options
- Specified from -40 °C to $+85$ °C and from -40 °C to $+125$ °C

PHILIPS

3. Applications

- Analog multiplexing and demultiplexing
- Digital multiplexing and demultiplexing
- Signal gating

4. Quick reference data

Table 1: Quick reference data

$V_{EE} = GND = 0\text{ V}$; $T_{amb} = 25\text{ °C}$; $t_r = t_f = 6\text{ ns}$.

Symbol	Parameter	Conditions	Min	Typ	Max	Unit
74HC4053						
t_{PZH} , t_{PZL}	turn-ON time	$C_L = 15\text{ pF}$; $R_L = 1\text{ k}\Omega$; $V_{CC} = 5\text{ V}$				
	\bar{E} to V_{OS}		-	17	-	ns
	Sn to V_{OS}		-	21	-	ns
t_{PHZ} , t_{PLZ}	turn-OFF time	$C_L = 15\text{ pF}$; $R_L = 1\text{ k}\Omega$; $V_{CC} = 5\text{ V}$				
	\bar{E} to V_{OS}		-	18	-	ns
	Sn to V_{OS}		-	17	-	ns
C_i	input capacitance		-	3.5	-	pF
C_S	switch capacitance					
	independent I/O (nYn)		-	5	-	pF
	common I/O (nZ)		-	8	-	pF
C_{PD}	power dissipation capacitance	per switch; $V_I = GND$ to V_{CC}	[1]	-	36	pF
74HCT4053						
t_{PZH} , t_{PZL}	turn-ON time	$C_L = 15\text{ pF}$; $R_L = 1\text{ k}\Omega$; $V_{CC} = 5\text{ V}$				
	\bar{E} to V_{OS}		-	23	-	ns
	Sn to V_{OS}		-	21	-	ns
t_{PHZ} , t_{PLZ}	turn-OFF time	$C_L = 15\text{ pF}$; $R_L = 1\text{ k}\Omega$; $V_{CC} = 5\text{ V}$				
	\bar{E} to V_{OS}		-	20	-	ns
	Sn to V_{OS}		-	19	-	ns
C_i	input capacitance		-	3.5	-	pF
C_S	switch capacitance					
	independent I/O (nYn)		-	5	-	pF
	common I/O(nZ)		-	8	-	pF
C_{PD}	power dissipation capacitance	per switch; $V_I = GND$ to $(V_{CC} - 1.5\text{ V})$	[1]	-	36	pF

[1] C_{PD} is used to determine the dynamic power dissipation (P_D in μW).

$P_D = C_{PD} \times V_{CC}^2 \times f_i + \sum\{(C_L + C_S) \times V_{CC}^2 \times f_o\}$ where:

f_i = input frequency in MHz;

f_o = output frequency in MHz;

$\sum\{(C_L + C_S) \times V_{CC}^2 \times f_o\}$ = sum of outputs;

C_L = output load capacitance in pF;
 C_S = maximum switch capacitance in pF;
 V_{CC} = supply voltage in V.

5. Ordering information

Table 2: Ordering information

Type number	Package			
	Temperature range	Name	Description	Version
74HC4053				
74HC4053N	-40 °C to +125 °C	DIP16	plastic dual in-line package; 16 leads (300 mil); long body	SOT38-4
74HC4053D	-40 °C to +125 °C	SO16	plastic small outline package; 16 leads; body width 3.9 mm	SOT109-1
74HC4053DB	-40 °C to +125 °C	SSOP16	plastic shrink small outline package; 16 leads; body width 5.3 mm	SOT338-1
74HC4053PW	-40 °C to +125 °C	TSSOP16	plastic thin shrink small outline package; 16 leads; body width 4.4 mm	SOT403-1
74HC4053BQ	-40 °C to +125 °C	DHVQFN16	plastic dual in-line compatible thermal enhanced very thin quad flat package; no leads; 16 terminals; body 2.5 × 3.5 × 0.85 mm	SOT763-1
74HCT4053				
74HCT4053N	-40 °C to +125 °C	DIP16	plastic dual in-line package; 16 leads (300 mil); long body	SOT38-4
74HCT4053D	-40 °C to +125 °C	SO16	plastic small outline package; 16 leads; body width 3.9 mm	SOT109-1
74HCT4053DB	-40 °C to +125 °C	SSOP16	plastic shrink small outline package; 16 leads; body width 5.3 mm	SOT338-1
74HCT4053PW	-40 °C to +125 °C	TSSOP16	plastic thin shrink small outline package; 16 leads; body width 4.4 mm	SOT403-1
74HCT4053BQ	-40 °C to +125 °C	DHVQFN16	plastic dual in-line compatible thermal enhanced very thin quad flat package; no leads; 16 terminals; body 2.5 × 3.5 × 0.85 mm	SOT763-1

7.2 Pin description

Table 3: Pin description

Symbol	Pin	Description
2Y1	1	2 independent input/output 1
2Y0	2	2 independent input/output 0
3Y1	3	3 independent input/output 1
3Z	4	3 common input/output
3Y0	5	3 independent input/output 0
\bar{E}	6	enable input (active LOW)
V_{EE}	7	negative supply voltage
GND	8	ground (0 V)
S3	9	select input 3
S2	10	select input 2
S1	11	select input 1
1Y0	12	1 independent input/output 0
1Y1	13	1 independent input/output 1
1Z	14	1 common input/output
2Z	15	2 common input/output
V_{CC}	16	supply voltage

8. Functional description

8.1 Function table

Table 4: Function table ^[1]

Control		Channel on
\bar{E}	S _n	
L	L	nY0 to nZ
	H	nY1 to nZ
H	X	none

[1] H = HIGH voltage level;
L = LOW voltage level;
X = don't care.

9. Limiting values

Table 5: Limiting values

In accordance with the Absolute Maximum Rating System (IEC 60134). Voltages are referenced to $V_{EE} = GND$ (ground = 0 V). ^[1]

Symbol	Parameter	Conditions	Min	Max	Unit
V_{CC}	supply voltage		-0.5	+11.0	V
I_{IK}	input clamping current	$V_I < -0.5\text{ V}$ or $V_I > V_{CC} + 0.5\text{ V}$	-	±20	mA
I_{SK}	switch clamping current	$V_S < -0.5\text{ V}$ or $V_S > V_{CC} + 0.5\text{ V}$	-	±20	mA

Table 5: Limiting values ...continued

In accordance with the Absolute Maximum Rating System (IEC 60134). Voltages are referenced to $V_{EE} = GND$ (ground = 0 V). [1]

Symbol	Parameter	Conditions	Min	Max	Unit	
I_S	switch current	$-0.5\text{ V} < V_S < V_{CC} + 0.5\text{ V}$	-	± 25	mA	
I_{EE}	negative supply current		-	-20	mA	
I_{CC}	quiescent supply current		-	50	mA	
I_{GND}	ground current		-	-50	mA	
T_{stg}	storage temperature		-65	+150	°C	
P_{tot}	total power dissipation	$T_{amb} = -40\text{ °C to } +125\text{ °C}$				
	DIP16 package		[2]	-	750	mW
	SO16 package		[3]	-	500	mW
	SSOP16 package		[4]	-	500	mW
	TSSOP16 package		[4]	-	500	mW
P_S	power dissipation per switch	DHVQFN16 package	[5]	-	500	mW

[1] To avoid drawing V_{CC} current out of terminals nZ, when switch current flows in terminals nYn, the voltage drop across the bidirectional switch must not exceed 0.4 V. If the switch current flows into terminals nZ, no V_{CC} current will flow out of terminals nYn. In this case there is no limit for the voltage drop across the switch, but the voltages at nYn and nZ may not exceed V_{CC} or V_{EE} .

[2] For DIP16 package: P_{tot} derates linearly with 12 mW/K above 70 °C.

[3] For SO16 package: P_{tot} derates linearly with 8 mW/K above 70 °C.

[4] For SSOP16 and TSSOP16 packages: P_{tot} derates linearly with 5.5 mW/K above 60 °C.

[5] For DHVQFN16 packages: P_{tot} derates linearly with 4.5 mW/K above 60 °C.

10. Recommended operating conditions

Table 6: Recommended operating conditions

Symbol	Parameter	Conditions	Min	Typ	Max	Unit
74HC4053						
ΔV_{CC}	supply voltage difference	see Figure 7				
	$V_{CC} - GND$		2.0	5.0	10.0	V
	$V_{CC} - V_{EE}$		2.0	5.0	10.0	V
V_I	input voltage		GND	-	V_{CC}	V
V_S	switch voltage		V_{EE}	-	V_{CC}	V
T_{amb}	ambient temperature		-40	+25	+125	°C
t_r, t_f	input rise and fall times	$V_{CC} = 2.0\text{ V}$	-	6.0	1000	ns
		$V_{CC} = 4.5\text{ V}$	-	6.0	500	ns
		$V_{CC} = 6.0\text{ V}$	-	6.0	400	ns
		$V_{CC} = 10.0\text{ V}$	-	6.0	250	ns
74HCT4053						
ΔV_{CC}	supply voltage difference	see Figure 7				
	$V_{CC} - GND$		4.5	5.0	5.5	V
	$V_{CC} - V_{EE}$		2.0	5.0	10.0	V

Table 6: Recommended operating conditions ...continued

Symbol	Parameter	Conditions	Min	Typ	Max	Unit
V_I	input voltage		GND	-	V_{CC}	V
V_S	switch voltage		V_{EE}	-	V_{CC}	V
T_{amb}	ambient temperature		-40	+25	+125	°C
t_r, t_f	input rise and fall times	$V_{CC} = 4.5\text{ V}$	-	6.0	500	ns

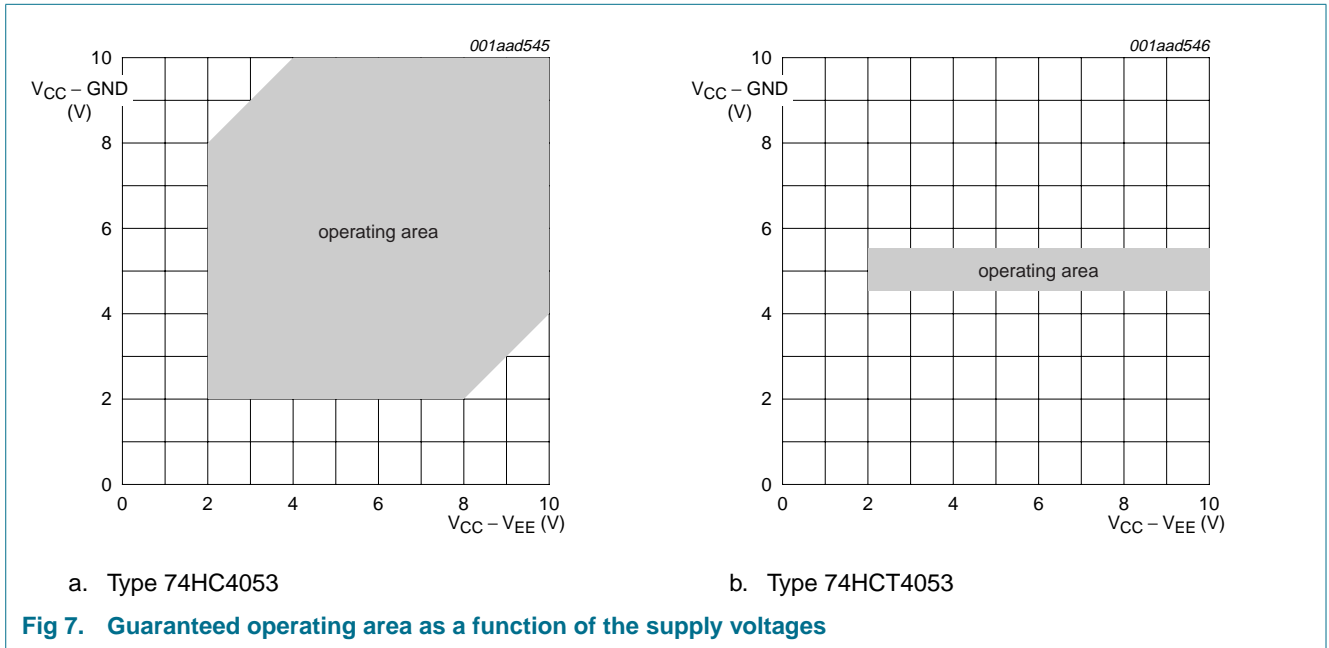

11. Static characteristics

Table 7: R_{ON} resistance per switch 74HC4053 and 74HCT4053

For test circuit see Figure 8.

V_{is} is the input voltage at a nYn or nZ terminal, whichever is assigned as an input.

V_{os} is the output voltage at a nYn or nZ terminal, whichever is assigned as an output.

74HC4053 supply voltages: $V_{CC} - GND$ or $V_{CC} - V_{EE} = 2.0\text{ V}, 4.5\text{ V}, 6.0\text{ V}$ and 9.0 V .

74HCT4053 supply voltages: $V_{CC} - GND = 4.5\text{ V}$ or 5.5 V ; $V_{CC} - V_{EE} = 2.0\text{ V}, 4.5\text{ V}, 6.0\text{ V}$ and 9.0 V .

Symbol	Parameter	Conditions	Min	Typ	Max	Unit
$T_{amb} = 25\text{ °C}$						
$R_{ON(peak)}$	ON resistance (peak)	$V_{is} = V_{CC}$ to V_{EE} ; $V_I = V_{IH}$ or V_{IL}				
		$V_{CC} = 2.0\text{ V}; V_{EE} = 0\text{ V}; I_S = 100\text{ }\mu\text{A}$	[1]	-	-	Ω
		$V_{CC} = 4.5\text{ V}; V_{EE} = 0\text{ V}; I_S = 1000\text{ }\mu\text{A}$	-	100	180	Ω
		$V_{CC} = 6.0\text{ V}; V_{EE} = 0\text{ V}; I_S = 1000\text{ }\mu\text{A}$	-	90	160	Ω
		$V_{CC} = 4.5\text{ V}; V_{EE} = -4.5\text{ V}; I_S = 1000\text{ }\mu\text{A}$	-	70	130	Ω

Table 7: R_{ON} resistance per switch 74HC4053 and 74HCT4053 ...continuedFor test circuit see [Figure 8](#). V_{is} is the input voltage at a nYn or nZ terminal, whichever is assigned as an input. V_{os} is the output voltage at a nYn or nZ terminal, whichever is assigned as an output.74HC4053 supply voltages: $V_{CC} - GND$ or $V_{CC} - V_{EE} = 2.0\text{ V}$, 4.5 V , 6.0 V and 9.0 V .74HCT4053 supply voltages: $V_{CC} - GND = 4.5\text{ V}$ or 5.5 V ; $V_{CC} - V_{EE} = 2.0\text{ V}$, 4.5 V , 6.0 V and 9.0 V .

Symbol	Parameter	Conditions	Min	Typ	Max	Unit	
$R_{ON(rail)}$	ON resistance (rail)	$V_{is} = V_{EE}$; $V_I = V_{IH}$ or V_{IL}					
		$V_{CC} = 2.0\text{ V}$; $V_{EE} = 0\text{ V}$; $I_S = 100\text{ }\mu\text{A}$	[1]	-	150	-	Ω
		$V_{CC} = 4.5\text{ V}$; $V_{EE} = 0\text{ V}$; $I_S = 1000\text{ }\mu\text{A}$	-	-	80	140	Ω
		$V_{CC} = 6.0\text{ V}$; $V_{EE} = 0\text{ V}$; $I_S = 1000\text{ }\mu\text{A}$	-	-	70	120	Ω
		$V_{CC} = 4.5\text{ V}$; $V_{EE} = -4.5\text{ V}$; $I_S = 1000\text{ }\mu\text{A}$	-	-	60	105	Ω
		$V_{is} = V_{CC}$; $V_I = V_{IH}$ or V_{IL}					
		$V_{CC} = 2.0\text{ V}$; $V_{EE} = 0\text{ V}$; $I_S = 100\text{ }\mu\text{A}$	[1]	-	150	-	Ω
		$V_{CC} = 4.5\text{ V}$; $V_{EE} = 0\text{ V}$; $I_S = 1000\text{ }\mu\text{A}$	-	-	90	160	Ω
		$V_{CC} = 6.0\text{ V}$; $V_{EE} = 0\text{ V}$; $I_S = 1000\text{ }\mu\text{A}$	-	-	80	140	Ω
		$V_{CC} = 4.5\text{ V}$; $V_{EE} = -4.5\text{ V}$; $I_S = 1000\text{ }\mu\text{A}$	-	-	65	120	Ω
ΔR_{ON}	ON resistance mismatch between channels	$V_{is} = V_{CC}$ to V_{EE} ; $V_I = V_{IH}$ or V_{IL}					
		$V_{CC} = 2.0\text{ V}$; $V_{EE} = 0\text{ V}$	[1]	-	-	-	Ω
		$V_{CC} = 4.5\text{ V}$; $V_{EE} = 0\text{ V}$	-	-	9	-	Ω
		$V_{CC} = 6.0\text{ V}$; $V_{EE} = 0\text{ V}$	-	-	8	-	Ω
		$V_{CC} = 4.5\text{ V}$; $V_{EE} = -4.5\text{ V}$	-	-	6	-	Ω
$T_{amb} = -40\text{ }^\circ\text{C}$ to $+85\text{ }^\circ\text{C}$							
$R_{ON(peak)}$	ON resistance (peak)	$V_{is} = V_{CC}$ to V_{EE} ; $V_I = V_{IH}$ or V_{IL}					
		$V_{CC} = 2.0\text{ V}$; $V_{EE} = 0\text{ V}$; $I_S = 100\text{ }\mu\text{A}$	[1]	-	-	-	Ω
		$V_{CC} = 4.5\text{ V}$; $V_{EE} = 0\text{ V}$; $I_S = 1000\text{ }\mu\text{A}$	-	-	-	225	Ω
		$V_{CC} = 6.0\text{ V}$; $V_{EE} = 0\text{ V}$; $I_S = 1000\text{ }\mu\text{A}$	-	-	-	200	Ω
		$V_{CC} = 4.5\text{ V}$; $V_{EE} = -4.5\text{ V}$; $I_S = 1000\text{ }\mu\text{A}$	-	-	-	165	Ω
$R_{ON(rail)}$	ON resistance (rail)	$V_{is} = V_{EE}$; $V_I = V_{IH}$ or V_{IL}					
		$V_{CC} = 2.0\text{ V}$; $V_{EE} = 0\text{ V}$; $I_S = 100\text{ }\mu\text{A}$	[1]	-	-	-	Ω
		$V_{CC} = 4.5\text{ V}$; $V_{EE} = 0\text{ V}$; $I_S = 1000\text{ }\mu\text{A}$	-	-	-	175	Ω
		$V_{CC} = 6.0\text{ V}$; $V_{EE} = 0\text{ V}$; $I_S = 1000\text{ }\mu\text{A}$	-	-	-	150	Ω
		$V_{CC} = 4.5\text{ V}$; $V_{EE} = -4.5\text{ V}$; $I_S = 1000\text{ }\mu\text{A}$	-	-	-	130	Ω
		$V_{is} = V_{CC}$; $V_I = V_{IH}$ or V_{IL}					
		$V_{CC} = 2.0\text{ V}$; $V_{EE} = 0\text{ V}$; $I_S = 100\text{ }\mu\text{A}$	[1]	-	-	-	Ω
		$V_{CC} = 4.5\text{ V}$; $V_{EE} = 0\text{ V}$; $I_S = 1000\text{ }\mu\text{A}$	-	-	-	200	Ω
		$V_{CC} = 6.0\text{ V}$; $V_{EE} = 0\text{ V}$; $I_S = 1000\text{ }\mu\text{A}$	-	-	-	175	Ω
		$V_{CC} = 4.5\text{ V}$; $V_{EE} = -4.5\text{ V}$; $I_S = 1000\text{ }\mu\text{A}$	-	-	-	150	Ω
$T_{amb} = -40\text{ }^\circ\text{C}$ to $+125\text{ }^\circ\text{C}$							
$R_{ON(peak)}$	ON resistance (peak)	$V_{is} = V_{CC}$ to V_{EE} ; $V_I = V_{IH}$ or V_{IL}					
		$V_{CC} = 2.0\text{ V}$; $V_{EE} = 0\text{ V}$; $I_S = 100\text{ }\mu\text{A}$	[1]	-	-	-	Ω
		$V_{CC} = 4.5\text{ V}$; $V_{EE} = 0\text{ V}$; $I_S = 1000\text{ }\mu\text{A}$	-	-	-	270	Ω
		$V_{CC} = 6.0\text{ V}$; $V_{EE} = 0\text{ V}$; $I_S = 1000\text{ }\mu\text{A}$	-	-	-	240	Ω
		$V_{CC} = 4.5\text{ V}$; $V_{EE} = -4.5\text{ V}$; $I_S = 1000\text{ }\mu\text{A}$	-	-	-	195	Ω

Table 7: R_{ON} resistance per switch 74HC4053 and 74HCT4053 ...continued

For test circuit see [Figure 8](#).

V_{is} is the input voltage at a nYn or nZ terminal, whichever is assigned as an input.

V_{os} is the output voltage at a nYn or nZ terminal, whichever is assigned as an output.

74HC4053 supply voltages: $V_{CC} - GND$ or $V_{CC} - V_{EE} = 2.0\text{ V}, 4.5\text{ V}, 6.0\text{ V}$ and 9.0 V .

74HCT4053 supply voltages: $V_{CC} - GND = 4.5\text{ V}$ or 5.5 V ; $V_{CC} - V_{EE} = 2.0\text{ V}, 4.5\text{ V}, 6.0\text{ V}$ and 9.0 V .

Symbol	Parameter	Conditions	Min	Typ	Max	Unit	
$R_{ON(rail)}$	ON resistance (rail)	$V_{is} = V_{EE}; V_I = V_{IH}$ or V_{IL}					
		$V_{CC} = 2.0\text{ V}; V_{EE} = 0\text{ V}; I_S = 100\text{ }\mu\text{A}$	[1]	-	-	-	Ω
		$V_{CC} = 4.5\text{ V}; V_{EE} = 0\text{ V}; I_S = 1000\text{ }\mu\text{A}$	-	-	210	Ω	
		$V_{CC} = 6.0\text{ V}; V_{EE} = 0\text{ V}; I_S = 1000\text{ }\mu\text{A}$	-	-	180	Ω	
		$V_{CC} = 4.5\text{ V}; V_{EE} = -4.5\text{ V}; I_S = 1000\text{ }\mu\text{A}$	-	-	160	Ω	
		$V_{is} = V_{CC}; V_I = V_{IH}$ or V_{IL}					
		$V_{CC} = 2.0\text{ V}; V_{EE} = 0\text{ V}; I_S = 100\text{ }\mu\text{A}$	[1]	-	-	-	Ω
		$V_{CC} = 4.5\text{ V}; V_{EE} = 0\text{ V}; I_S = 1000\text{ }\mu\text{A}$	-	-	240	Ω	
		$V_{CC} = 6.0\text{ V}; V_{EE} = 0\text{ V}; I_S = 1000\text{ }\mu\text{A}$	-	-	210	Ω	
		$V_{CC} = 4.5\text{ V}; V_{EE} = -4.5\text{ V}; I_S = 1000\text{ }\mu\text{A}$	-	-	180	Ω	

[1] At supply voltages ($V_{CC} - V_{EE}$) approaching 2.0 V the analog switch ON resistance becomes extremely non-linear. Therefore, it is recommended that these devices be used to transmit digital signals only, when using these supply voltages.

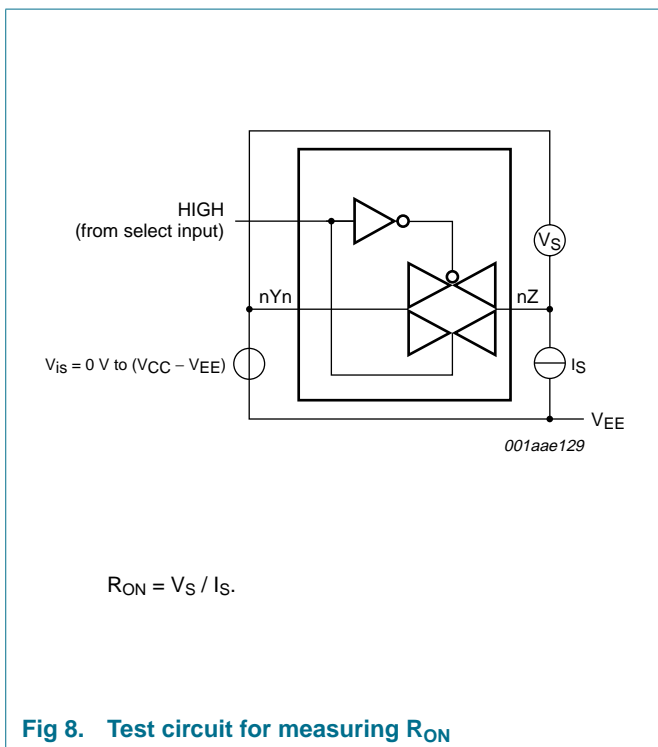

Fig 8. Test circuit for measuring R_{ON}

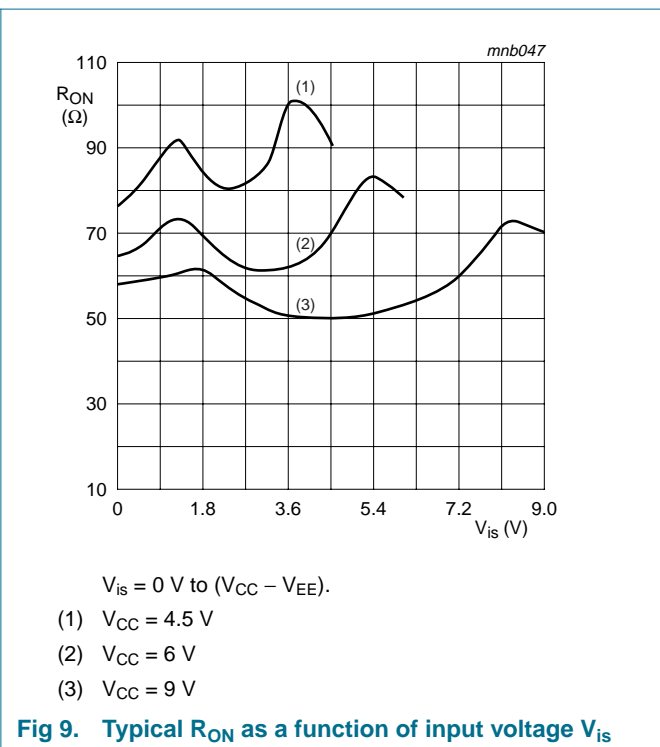

Fig 9. Typical R_{ON} as a function of input voltage V_{is}

Table 8: Static characteristics 74HC4053

At recommended operating conditions; voltages are referenced to GND (ground = 0 V).

V_{is} is the input voltage at a nYn or nZ terminal, whichever is assigned as an input.

V_{os} is the output voltage at a nYn or nZ terminal, whichever is assigned as an output.

Symbol	Parameter	Conditions	Min	Typ	Max	Unit
$T_{amb} = 25\text{ °C}$						
V_{IH}	HIGH-state input voltage	$V_{CC} = 2.0\text{ V}$	1.5	1.2	-	V
		$V_{CC} = 4.5\text{ V}$	3.15	2.4	-	V
		$V_{CC} = 6.0\text{ V}$	4.2	3.2	-	V
		$V_{CC} = 9.0\text{ V}$	6.3	4.7	-	V
V_{IL}	LOW-state input voltage	$V_{CC} = 2.0\text{ V}$	-	0.8	0.5	V
		$V_{CC} = 4.5\text{ V}$	-	2.1	1.35	V
		$V_{CC} = 6.0\text{ V}$	-	2.8	1.8	V
		$V_{CC} = 9.0\text{ V}$	-	4.3	2.7	V
I_{LI}	input leakage current	$V_I = V_{CC}$ or GND; $V_{EE} = 0\text{ V}$				
		$V_{CC} = 6.0\text{ V}$	-	-	± 0.1	μA
		$V_{CC} = 10.0\text{ V}$	-	-	± 0.2	μA
$I_{S(OFF)}$	OFF-state leakage current	$V_{CC} = 10.0\text{ V}$; $V_I = V_{IH}$ or V_{IL} ; $V_{EE} = 0\text{ V}$; $ V_S = V_{CC} - V_{EE}$; see Figure 10				
		per channel	-	-	± 0.1	μA
		all channels	-	-	± 0.1	μA
$I_{S(ON)}$	ON-state leakage current	$V_{CC} = 10.0\text{ V}$; $V_I = V_{IH}$ or V_{IL} ; $V_{EE} = 0\text{ V}$; $ V_S = V_{CC} - V_{EE}$; see Figure 11	-	-	± 0.1	μA
I_{CC}	quiescent supply current	$V_{is} = V_{EE}$ or V_{CC} ; $V_{os} = V_{CC}$ or V_{EE} ; $V_I = V_{CC}$ or GND; $V_{EE} = 0\text{ V}$				
		$V_{CC} = 6.0\text{ V}$	-	-	8.0	μA
		$V_{CC} = 10.0\text{ V}$	-	-	16.0	μA
C_i	input capacitance		-	3.5	-	pF
C_S	switch capacitance	independent I/O (nYn)	-	5	-	pF
		common I/O (nZ)	-	8	-	pF
$T_{amb} = -40\text{ °C to }+85\text{ °C}$						
V_{IH}	HIGH-state input voltage	$V_{CC} = 2.0\text{ V}$	1.5	-	-	V
		$V_{CC} = 4.5\text{ V}$	3.15	-	-	V
		$V_{CC} = 6.0\text{ V}$	4.2	-	-	V
		$V_{CC} = 9.0\text{ V}$	6.3	-	-	V
V_{IL}	LOW-state input voltage	$V_{CC} = 2.0\text{ V}$	-	-	0.5	V
		$V_{CC} = 4.5\text{ V}$	-	-	1.35	V
		$V_{CC} = 6.0\text{ V}$	-	-	1.8	V
		$V_{CC} = 9.0\text{ V}$	-	-	2.7	V
I_{LI}	input leakage current	$V_I = V_{CC}$ or GND; $V_{EE} = 0\text{ V}$				
		$V_{CC} = 6.0\text{ V}$	-	-	± 1.0	μA
		$V_{CC} = 10.0\text{ V}$	-	-	± 2.0	μA

Table 8: Static characteristics 74HC4053 ...continued

At recommended operating conditions; voltages are referenced to GND (ground = 0 V).

V_{is} is the input voltage at a nYn or nZ terminal, whichever is assigned as an input.

V_{os} is the output voltage at a nYn or nZ terminal, whichever is assigned as an output.

Symbol	Parameter	Conditions	Min	Typ	Max	Unit
$I_{S(OFF)}$	OFF-state leakage current	$V_{CC} = 10.0\text{ V}$; $V_I = V_{IH}$ or V_{IL} ; $V_{EE} = 0\text{ V}$; $ V_S = V_{CC} - V_{EE}$; see Figure 10				
		per channel	-	-	± 1.0	μA
		all channels	-	-	± 1.0	μA
$I_{S(ON)}$	ON-state leakage current	$V_{CC} = 10.0\text{ V}$; $V_I = V_{IH}$ or V_{IL} ; $V_{EE} = 0\text{ V}$; $ V_S = V_{CC} - V_{EE}$; see Figure 11	-	-	± 1.0	μA
I_{CC}	quiescent supply current	$V_{is} = V_{EE}$ or V_{CC} ; $V_{os} = V_{CC}$ or V_{EE} ; $V_I = V_{CC}$ or GND; $V_{EE} = 0\text{ V}$				
		$V_{CC} = 6.0\text{ V}$	-	-	80.0	μA
		$V_{CC} = 10.0\text{ V}$	-	-	160.0	μA
$T_{amb} = -40\text{ }^\circ\text{C}$ to $+125\text{ }^\circ\text{C}$						
V_{IH}	HIGH-state input voltage	$V_{CC} = 2.0\text{ V}$	1.5	-	-	V
		$V_{CC} = 4.5\text{ V}$	3.15	-	-	V
		$V_{CC} = 6.0\text{ V}$	4.2	-	-	V
		$V_{CC} = 9.0\text{ V}$	6.3	-	-	V
V_{IL}	LOW-state input voltage	$V_{CC} = 2.0\text{ V}$	-	-	0.5	V
		$V_{CC} = 4.5\text{ V}$	-	-	1.35	V
		$V_{CC} = 6.0\text{ V}$	-	-	1.8	V
		$V_{CC} = 9.0\text{ V}$	-	-	2.7	V
I_{LI}	input leakage current	$V_I = V_{CC}$ or GND; $V_{EE} = 0\text{ V}$				
		$V_{CC} = 6.0\text{ V}$	-	-	± 1.0	μA
		$V_{CC} = 10.0\text{ V}$	-	-	± 2.0	μA
$I_{S(OFF)}$	OFF-state leakage current	$V_{CC} = 10.0\text{ V}$; $V_I = V_{IH}$ or V_{IL} ; $V_{EE} = 0\text{ V}$; $ V_S = V_{CC} - V_{EE}$; see Figure 10				
		per channel	-	-	± 1.0	μA
		all channels	-	-	± 1.0	μA
$I_{S(ON)}$	ON-state leakage current	$V_{CC} = 10.0\text{ V}$; $V_I = V_{IH}$ or V_{IL} ; $V_{EE} = 0\text{ V}$; $ V_S = V_{CC} - V_{EE}$; see Figure 11	-	-	± 1.0	μA
I_{CC}	quiescent supply current	$V_{is} = V_{EE}$ or V_{CC} ; $V_{os} = V_{CC}$ or V_{EE} ; $V_I = V_{CC}$ or GND; $V_{EE} = 0\text{ V}$				
		$V_{CC} = 6.0\text{ V}$	-	-	160.0	μA
		$V_{CC} = 10.0\text{ V}$	-	-	320.0	μA

Table 9: Static characteristics 74HCT4053

Voltages are referenced to GND (ground = 0 V).

V_{is} is the input voltage at a nYn or nZ terminal, whichever is assigned as an input.

V_{os} is the output voltage at a nYn or nZ terminal, whichever is assigned as an output.

Symbol	Parameter	Conditions	Min	Typ	Max	Unit
$T_{amb} = 25\text{ }^\circ\text{C}$						
V_{IH}	HIGH-state input voltage	$V_{CC} = 4.5\text{ V}$ to 5.5 V	2.0	1.6	-	μA
V_{IL}	LOW-state input voltage	$V_{CC} = 4.5\text{ V}$ to 5.5 V	-	1.2	0.8	μA

Table 9: Static characteristics 74HCT4053 ...continued

Voltages are referenced to GND (ground = 0 V).

V_{is} is the input voltage at a nYn or nZ terminal, whichever is assigned as an input.

V_{os} is the output voltage at a nYn or nZ terminal, whichever is assigned as an output.

Symbol	Parameter	Conditions	Min	Typ	Max	Unit
$I_{S(OFF)}$	OFF-state leakage current	$V_{CC} = 10.0\text{ V}$; $V_I = V_{IH}$ or V_{IL} ; $V_{EE} = 0\text{ V}$; $ V_S = V_{CC} - V_{EE}$; see Figure 10				
		per channel	-	-	± 1.0	μA
		all channels	-	-	± 1.0	μA
$I_{S(ON)}$	ON-state leakage current	$V_{CC} = 10.0\text{ V}$; $V_I = V_{IH}$ or V_{IL} ; $V_{EE} = 0\text{ V}$; $ V_S = V_{CC} - V_{EE}$; see Figure 11	-	-	± 1.0	μA
I_{CC}	quiescent supply current	$V_I = V_{CC}$ or GND; $V_{is} = V_{EE}$ or V_{CC} ; $V_{os} = V_{CC}$ or V_{EE}				
		$V_{CC} = 5.5\text{ V}$; $V_{EE} = 0\text{ V}$	-	-	160.0	μA
		$V_{CC} = 5.0\text{ V}$; $V_{EE} = -5.0\text{ V}$	-	-	320.0	μA
ΔI_{CC}	additional quiescent supply current	per input pin; $V_{CC} = 4.5\text{ V}$ to 5.5 V ; $V_{EE} = 0\text{ V}$; $V_I = V_{CC} - 2.1\text{ V}$; other inputs at V_{CC} or GND	-	-	245	μA

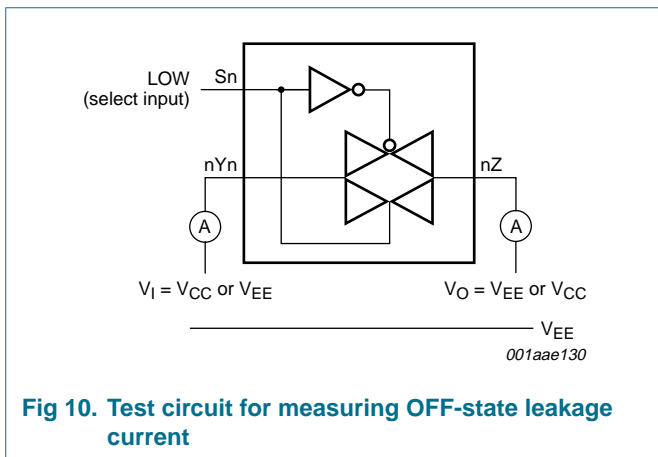

Fig 10. Test circuit for measuring OFF-state leakage current

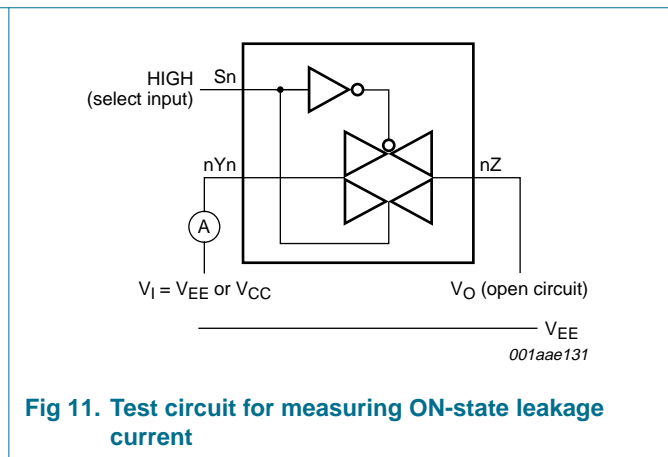

Fig 11. Test circuit for measuring ON-state leakage current

12. Dynamic characteristics

Table 10: Dynamic characteristics type 74HC4053

Voltages are referenced to GND (ground = 0 V); $t_r = t_f = 6\text{ ns}$; $C_L = 50\text{ pF}$ unless otherwise specified; for test circuit see [Figure 14](#).

V_{is} is the input voltage at a nYn or nZ terminal, whichever is assigned as an input.

V_{os} is the output voltage at a nYn or nZ terminal, whichever is assigned as an output.

Symbol	Parameter	Conditions	Min	Typ	Max	Unit
$T_{amb} = 25\text{ }^\circ\text{C}$						
t_{PHL} , t_{PLH}	propagation delay V_{is} to V_{os}	$R_L = \infty\ \Omega$; see Figure 12				
		$V_{CC} = 2.0\text{ V}$; $V_{EE} = 0\text{ V}$	-	15	60	ns
		$V_{CC} = 4.5\text{ V}$; $V_{EE} = 0\text{ V}$	-	5	12	ns
		$V_{CC} = 6.0\text{ V}$; $V_{EE} = 0\text{ V}$	-	4	10	ns
		$V_{CC} = 4.5\text{ V}$; $V_{EE} = -4.5\text{ V}$	-	4	8	ns

Table 10: Dynamic characteristics type 74HC4053 ...continued

Voltages are referenced to GND (ground = 0 V); $t_r = t_f = 6$ ns; $C_L = 50$ pF unless otherwise specified; for test circuit see Figure 14.

V_{is} is the input voltage at a nYn or nZ terminal, whichever is assigned as an input.

V_{os} is the output voltage at a nYn or nZ terminal, whichever is assigned as an output.

Symbol	Parameter	Conditions	Min	Typ	Max	Unit	
t_{PZH} , t_{PZL}	turn-ON time \bar{E} to V_{os}	$R_L = 1$ k Ω ; see Figure 13					
		$V_{CC} = 2.0$ V; $V_{EE} = 0$ V	-	60	220	ns	
		$V_{CC} = 4.5$ V; $V_{EE} = 0$ V	-	20	44	ns	
		$V_{CC} = 6.0$ V; $V_{EE} = 0$ V	-	16	37	ns	
		$V_{CC} = 4.5$ V; $V_{EE} = -4.5$ V	-	15	31	ns	
		$V_{CC} = 5$ V; $V_{EE} = 0$ V; $C_L = 15$ pF	-	17	-	ns	
	Sn to V_{os}	$V_{CC} = 2.0$ V; $V_{EE} = 0$ V	-	75	220	ns	
		$V_{CC} = 4.5$ V; $V_{EE} = 0$ V	-	25	44	ns	
		$V_{CC} = 6.0$ V; $V_{EE} = 0$ V	-	20	37	ns	
		$V_{CC} = 4.5$ V; $V_{EE} = -4.5$ V	-	15	31	ns	
		$V_{CC} = 5$ V; $V_{EE} = 0$ V; $C_L = 15$ pF	-	21	-	ns	
t_{PHZ} , t_{PLZ}	turn-OFF time \bar{E} to V_{os}	$R_L = 1$ k Ω ; see Figure 13					
		$V_{CC} = 2.0$ V; $V_{EE} = 0$ V	-	63	210	ns	
		$V_{CC} = 4.5$ V; $V_{EE} = 0$ V	-	21	42	ns	
		$V_{CC} = 6.0$ V; $V_{EE} = 0$ V	-	17	36	ns	
		$V_{CC} = 4.5$ V; $V_{EE} = -4.5$ V	-	15	29	ns	
		$V_{CC} = 5$ V; $C_L = 15$ pF	-	18	-	ns	
	Sn to V_{os}	$V_{CC} = 2.0$ V; $V_{EE} = 0$ V	-	60	210	ns	
		$V_{CC} = 4.5$ V; $V_{EE} = 0$ V	-	20	42	ns	
		$V_{CC} = 6.0$ V; $V_{EE} = 0$ V	-	16	36	ns	
		$V_{CC} = 4.5$ V; $V_{EE} = -4.5$ V	-	15	29	ns	
		$V_{CC} = 5$ V; $C_L = 15$ pF	-	17	-	ns	
C_{PD}	power dissipation capacitance	per switch; $V_I = \text{GND to } V_{CC}$	[1]	-	36	-	pF

$T_{amb} = -40$ °C to $+85$ °C

t_{PHL} , t_{PLH}	propagation delay V_{is} to V_{os}	$R_L = \infty$ Ω ; see Figure 12				
		$V_{CC} = 2.0$ V; $V_{EE} = 0$ V	-	-	75	ns
		$V_{CC} = 4.5$ V; $V_{EE} = 0$ V	-	-	15	ns
		$V_{CC} = 6.0$ V; $V_{EE} = 0$ V	-	-	13	ns
		$V_{CC} = 4.5$ V; $V_{EE} = -4.5$ V	-	-	10	ns

Table 10: Dynamic characteristics type 74HC4053 ...continued

Voltages are referenced to GND (ground = 0 V); $t_r = t_f = 6$ ns; $C_L = 50$ pF unless otherwise specified; for test circuit see Figure 14.

V_{is} is the input voltage at a nYn or nZ terminal, whichever is assigned as an input.

V_{os} is the output voltage at a nYn or nZ terminal, whichever is assigned as an output.

Symbol	Parameter	Conditions	Min	Typ	Max	Unit
t_{PZH} , t_{PZL}	turn-ON time	$R_L = 1$ k Ω ; see Figure 13				
	\bar{E} to V_{os}	$V_{CC} = 2.0$ V; $V_{EE} = 0$ V	-	-	275	ns
		$V_{CC} = 4.5$ V; $V_{EE} = 0$ V	-	-	55	ns
		$V_{CC} = 6.0$ V; $V_{EE} = 0$ V	-	-	47	ns
		$V_{CC} = 4.5$ V; $V_{EE} = -4.5$ V	-	-	39	ns
	Sn to V_{os}	$V_{CC} = 2.0$ V; $V_{EE} = 0$ V	-	-	275	ns
		$V_{CC} = 4.5$ V; $V_{EE} = 0$ V	-	-	55	ns
		$V_{CC} = 6.0$ V; $V_{EE} = 0$ V	-	-	47	ns
		$V_{CC} = 4.5$ V; $V_{EE} = -4.5$ V	-	-	39	ns
t_{PHZ} , t_{PLZ}	turn-OFF time	$R_L = 1$ k Ω ; see Figure 13				
	\bar{E} to V_{os}	$V_{CC} = 2.0$ V; $V_{EE} = 0$ V	-	-	265	ns
		$V_{CC} = 4.5$ V; $V_{EE} = 0$ V	-	-	53	ns
		$V_{CC} = 6.0$ V; $V_{EE} = 0$ V	-	-	45	ns
		$V_{CC} = 4.5$ V; $V_{EE} = -4.5$ V	-	-	36	ns
	Sn to V_{os}	$V_{CC} = 2.0$ V; $V_{EE} = 0$ V	-	-	265	ns
		$V_{CC} = 4.5$ V; $V_{EE} = 0$ V	-	-	53	ns
		$V_{CC} = 6.0$ V; $V_{EE} = 0$ V	-	-	45	ns
		$V_{CC} = 4.5$ V; $V_{EE} = -4.5$ V	-	-	36	ns
$T_{amb} = -40$ °C to $+125$ °C						
t_{PHL} , t_{PLH}	propagation delay V_{is} to V_{os}	$R_L = \infty$ Ω ; see Figure 12				
		$V_{CC} = 2.0$ V; $V_{EE} = 0$ V	-	-	90	ns
		$V_{CC} = 4.5$ V; $V_{EE} = 0$ V	-	-	18	ns
		$V_{CC} = 6.0$ V; $V_{EE} = 0$ V	-	-	15	ns
		$V_{CC} = 4.5$ V; $V_{EE} = -4.5$ V	-	-	12	ns
t_{PZH} , t_{PZL}	turn-ON time	$R_L = 1$ k Ω ; see Figure 13				
	\bar{E} to V_{os}	$V_{CC} = 2.0$ V; $V_{EE} = 0$ V	-	-	330	ns
		$V_{CC} = 4.5$ V; $V_{EE} = 0$ V	-	-	66	ns
		$V_{CC} = 6.0$ V; $V_{EE} = 0$ V	-	-	56	ns
		$V_{CC} = 4.5$ V; $V_{EE} = -4.5$ V	-	-	47	ns
	Sn to V_{os}	$V_{CC} = 2.0$ V; $V_{EE} = 0$ V	-	-	330	ns
		$V_{CC} = 4.5$ V; $V_{EE} = 0$ V	-	-	66	ns
		$V_{CC} = 6.0$ V; $V_{EE} = 0$ V	-	-	56	ns
		$V_{CC} = 4.5$ V; $V_{EE} = -4.5$ V	-	-	47	ns

Table 10: Dynamic characteristics type 74HC4053 ...continued

Voltages are referenced to GND (ground = 0 V); $t_r = t_f = 6$ ns; $C_L = 50$ pF unless otherwise specified; for test circuit see Figure 14.

V_{is} is the input voltage at a nYn or nZ terminal, whichever is assigned as an input.

V_{os} is the output voltage at a nYn or nZ terminal, whichever is assigned as an output.

Symbol	Parameter	Conditions	Min	Typ	Max	Unit
t_{PHZ} , t_{PLZ}	turn-OFF time	$R_L = 1$ k Ω ; see Figure 13				
	\bar{E} to V_{os}	$V_{CC} = 2.0$ V; $V_{EE} = 0$ V	-	-	315	ns
		$V_{CC} = 4.5$ V; $V_{EE} = 0$ V	-	-	63	ns
		$V_{CC} = 6.0$ V; $V_{EE} = 0$ V	-	-	54	ns
		$V_{CC} = 4.5$ V; $V_{EE} = -4.5$ V	-	-	44	ns
	Sn to V_{os}	$V_{CC} = 2.0$ V; $V_{EE} = 0$ V	-	-	315	ns
		$V_{CC} = 4.5$ V; $V_{EE} = 0$ V	-	-	63	ns
		$V_{CC} = 6.0$ V; $V_{EE} = 0$ V	-	-	54	ns
		$V_{CC} = 4.5$ V; $V_{EE} = -4.5$ V	-	-	44	ns

[1] C_{PD} is used to determine the dynamic power dissipation (P_D in μ W):

$$P_D = C_{PD} \times V_{CC}^2 \times f_i + \sum\{(C_L + C_S) \times V_{CC}^2 \times f_o\} \text{ where:}$$

f_i = input frequency in MHz;

f_o = output frequency in MHz;

$\sum\{(C_L + C_S) \times V_{CC}^2 \times f_o\}$ = sum of outputs;

C_L = output load capacitance in pF;

C_S = maximum switch capacitance in pF;

V_{CC} = supply voltage in V.

Table 11: Dynamic characteristics type 74HCT4053

Voltages are referenced to GND (ground = 0 V); $t_r = t_f = 6$ ns; $C_L = 50$ pF unless otherwise specified; for test circuit see Figure 14.

V_{is} is the input voltage at a nYn or nZ terminal, whichever is assigned as an input.

V_{os} is the output voltage at a nYn or nZ terminal, whichever is assigned as an output.

Symbol	Parameter	Conditions	Min	Typ	Max	Unit
$T_{amb} = 25$ °C						
t_{PHL} , t_{PLH}	propagation delay V_{is} to V_{os}	$V_{CC} = 4.5$ V; $R_L = \infty$ Ω ; see Figure 12				
		$V_{EE} = 0$ V	-	5	12	ns
		$V_{EE} = -4.5$ V	-	4	8	ns
t_{PZH} , t_{PZL}	turn-ON time	$R_L = 1$ k Ω ; see Figure 13				
	\bar{E} to V_{os}	$V_{CC} = 4.5$ V; $V_{EE} = 0$ V	-	27	48	ns
		$V_{CC} = 4.5$ V; $V_{EE} = -4.5$ V	-	16	34	ns
		$V_{CC} = 5$ V; $V_{EE} = 0$ V; $C_L = 15$ pF	-	23	-	ns
	Sn to V_{os}	$V_{CC} = 4.5$ V; $V_{EE} = 0$ V	-	25	48	ns
		$V_{CC} = 4.5$ V; $V_{EE} = -4.5$ V	-	16	34	ns
		$V_{CC} = 5$ V; $V_{EE} = 0$ V; $C_L = 15$ pF	-	21	-	ns

14. Additional dynamic characteristics

Table 14: Additional dynamic characteristics 74HC4053 and 74HCT4053

$GND = 0\text{ V}$; $T_{amb} = 25\text{ }^\circ\text{C}$.

V_{is} is the input voltage at an nYn or nZ terminal, whichever is assigned as an input.

V_{os} is the output voltage at an nYn or nZ terminal, whichever is assigned as an output.

Symbol	Parameter	Conditions	Min	Typ	Max	Unit
d_{sin}	sine wave distortion	$R_L = 10\text{ k}\Omega$; $C_L = 50\text{ pF}$; see Figure 15				
		$f_i = 1\text{ kHz}$				
		$V_{CC} = 2.25\text{ V}$; $V_{EE} = -2.25\text{ V}$; $V_{is} = 4.0\text{ V (p-p)}$	-	0.04	-	%
		$V_{CC} = 4.5\text{ V}$; $V_{EE} = -4.5\text{ V}$; $V_{is} = 8.0\text{ V (p-p)}$	-	0.02	-	%
		$f_i = 10\text{ kHz}$				
		$V_{CC} = 2.25\text{ V}$; $V_{EE} = -2.25\text{ V}$; $V_{is} = 4.0\text{ V (p-p)}$	-	0.12	-	%
$\alpha_{(OFF)(ft)}$	OFF-state feed-through attenuation	$R_L = 600\text{ }\Omega$; $C_L = 50\text{ pF}$; $f_i = 1\text{ MHz}$; see Figure 16	[1]			
		$V_{CC} = 2.25\text{ V}$; $V_{EE} = -2.25\text{ V}$	-	-50	-	dB
		$V_{CC} = 4.5\text{ V}$; $V_{EE} = -4.5\text{ V}$	-	-50	-	dB
$V_{ct(sw-sw)}$	crosstalk between switches	$R_L = 600\text{ }\Omega$; $C_L = 50\text{ pF}$; $f_i = 1\text{ MHz}$; see Figure 17	[1]			
		$V_{CC} = 2.25\text{ V}$; $V_{EE} = -2.25\text{ V}$	-	-60	-	dB
		$V_{CC} = 4.5\text{ V}$; $V_{EE} = -4.5\text{ V}$	-	-60	-	dB
$V_{ct(d-sw)}$	crosstalk between digital inputs and switch	$V_{CC} = 4.5\text{ V}$; $R_L = 600\text{ k}\Omega$; $C_L = 50\text{ pF}$; $f_i = 1\text{ MHz}$; see Figure 18	[2]			
		$V_{EE} = 0\text{ V}$	-	110	-	mV
		$V_{EE} = -4.5\text{ V}$	-	220	-	mV
$f_{(-3dB)}$	-3 dB frequency response	$R_L = 50\text{ }\Omega$; $C_L = 10\text{ pF}$; see Figure 19	[3]			
		$V_{CC} = 2.25\text{ V}$; $V_{EE} = -2.25\text{ V}$	-	160	-	MHz
		$V_{CC} = 4.5\text{ V}$; $V_{EE} = -4.5\text{ V}$	-	170	-	MHz

- [1] Adjust input voltage V_{is} to 0 dBm level (0 dBm = 1 mW into 600 Ω).
- [2] Control input \bar{E} or S_n , with square-wave between V_{CC} and GND.
- [3] Adjust input voltage V_{is} to 0 dBm level at V_{os} for 1 MHz (0 dBm = 1 mW into 50 Ω).

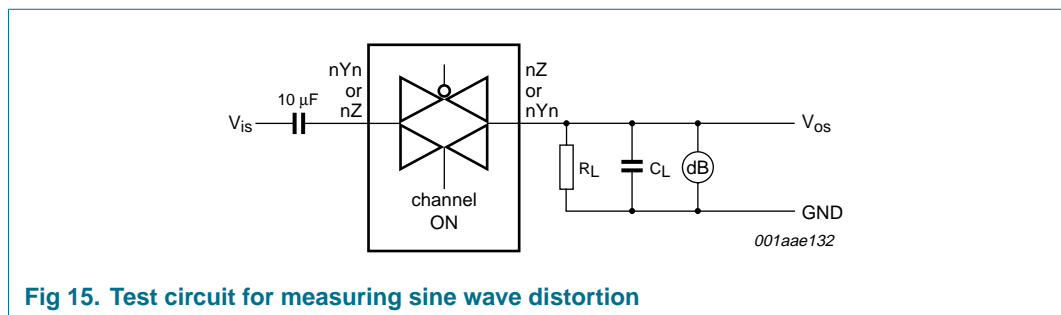
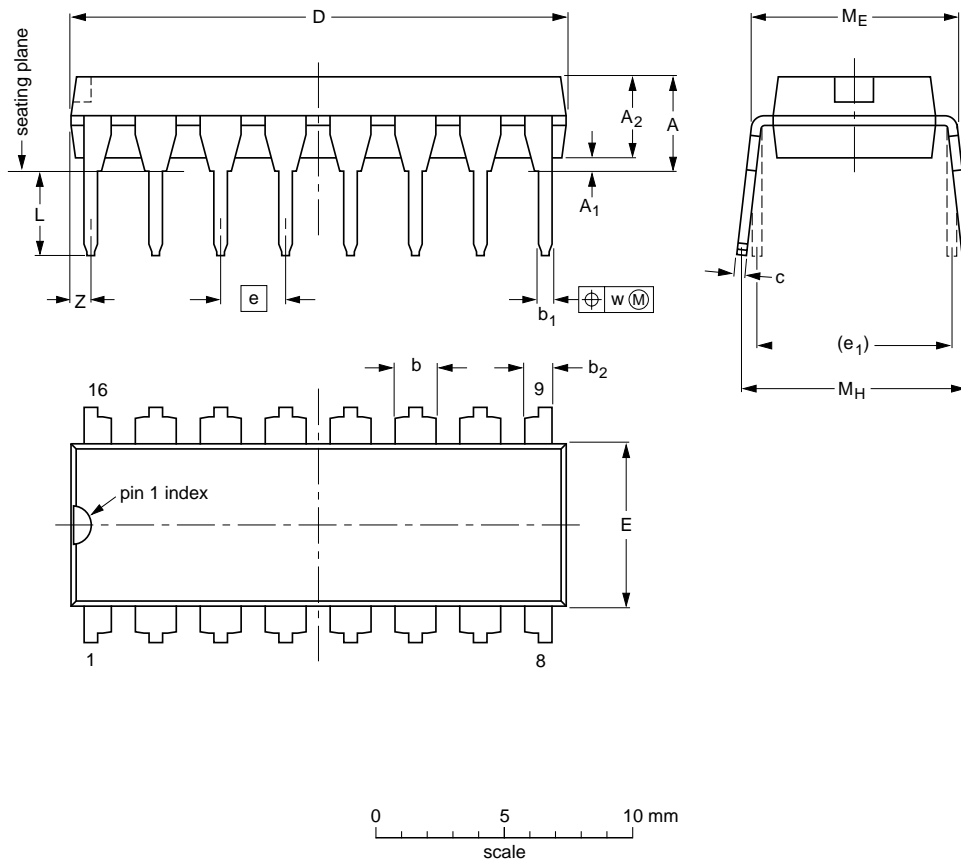

Fig 15. Test circuit for measuring sine wave distortion

15. Package outline

DIP16: plastic dual in-line package; 16 leads (300 mil)

SOT38-4



DIMENSIONS (inch dimensions are derived from the original mm dimensions)

UNIT	A max.	A1 min.	A2 max.	b	b1	b2	c	D ⁽¹⁾	E ⁽¹⁾	e	e1	L	ME	MH	w	Z ⁽¹⁾ max.
mm	4.2	0.51	3.2	1.73 1.30	0.53 0.38	1.25 0.85	0.36 0.23	19.50 18.55	6.48 6.20	2.54	7.62	3.60 3.05	8.25 7.80	10.0 8.3	0.254	0.76
inches	0.17	0.02	0.13	0.068 0.051	0.021 0.015	0.049 0.033	0.014 0.009	0.77 0.73	0.26 0.24	0.1	0.3	0.14 0.12	0.32 0.31	0.39 0.33	0.01	0.03

Note

1. Plastic or metal protrusions of 0.25 mm (0.01 inch) maximum per side are not included.

OUTLINE VERSION	REFERENCES				EUROPEAN PROJECTION
	IEC	JEDEC	JEITA		
SOT38-4					

Fig 20. Package outline SOT38-4 (DIP16)